



SLI-30

OPERATING MANUAL

NOTE:

Before installing your new SLI -30, please read this manual carefully as it will inform you of the SLI-30's specifications, proper installation procedures and operation procedures. Also included in this manual are guidelines on how to properly service and care for your new SLI-30.

SLI-30 INTEGRATED STEREO AMPLIFIER

Congratulations! You have purchased one of the most exotic integrated stereo audio amplifiers available. Within its power range, the SLI-30 displays the operating characteristics of a true "high-end" amplifier. Careful design, parts selection and proper circuit topologies contribute to incredible reliability and enjoyment.

For the technically minded, a review of the circuit is in order. Your new SLI-30 operates in a class A mode utilizing (auto bias) cathode self-biasing on the EL-84 (6BQ5) output tubes. The EL-84 output tubes are operating in a push-pull configuration utilizing the simple but effective system of a tapped-screen "ultra-linear" circuit. The ultra-linear circuit combines the advantages of triodes and pentodes, thus providing greater sensitivity, extremely low distortion and improved transient response. The output transformer in your SLI-30 is the most important component in the amplifier and has been specifically designed by Cary Audio for use in the SLI-30. Negative feedback is used to reduce the noise floor and improve the speaker damping characteristics. Only 3dB of feedback is utilized since the output transformer and circuit design was originally designed without feedback. The phase inverter is a self-balancing split load configuration utilizing one-half of the 12AX7 input tubes. The other section of the 12AX7 is the input preamplification section of the SLI-30. This input circuit is a resistive coupled Class A triode voltage amplifier stage. The power supply in the SLI-30 features a 150% duty cycle EI laminate power transformer. The high voltage section features full wave rectification (not cheap voltage doublers used in many amplifiers) to a PI-L capacitive network. To avoid AC hum, the input 12AX7 tubes have 12 VDC regulated filament voltage. This will prevent AC ripple voltage from capacitively being coupled to electrodes in the gain stage of the 12AX7. The input signal from the volume control is direct coupled (DC) to the first grid of the 12AX7. There are no coupling capacitors in line with the input signal on the SLI-30. A block diagram of your new SLI-30 has been provided in this manual for your reference.

A great deal of attention during design of your new SLI-30 was concentrated on the "overload recovery" ability of the amplifier. The ability of an amplifier to instantly recover from clipping is much more important than is commonly believed. In the power war of amplifier manufactures the mentality is focused on high and then even higher power output to solve the clipping problem. When in reality the most critical aspect is how fast of a recovery an amplifier can achieve after overload. With the incredible dynamic range of live and in turn recorded music, even 2,000 watts of power is not enough. Most of the music being listened to in an average listening room is only requiring about 3 watts of power. It is on the transients of loud low frequency program material that tremendous signal voltages will appear at the input of the amplifier. It is in this situation that the overload recovery ability of an amplifier is of critical concern. The SLI-30 extols its merits in the ability to handle transients and instantaneously recover from brief or even extended overloads. The SLI-30 will overload symmetrically at any frequency in the audio bandpass. The SLI-30 will also yield faithful reproduction of

extremely low frequencies at full output levels. Power transformer, power supply regulation and output transformer design and careful shaping of the overall frequency response curve all play a very important part in the ability of the SLI-30 to recover quickly when overloaded. If one were to monitor the high voltage rail voltage (330 VDC) of an SLI-30 during soft and also loud music passages it will be found there is no more than a volt or so change from soft to loud passages.

Another technical feature of your new SLI-30 amplifier is stability. The SLI-30 may be operated with no load (without speaker) without damage to the amplifier, output transformer or tubes.

The most exciting feature of your new SLI-30, aside from how compact and gorgeous it looks, is the delightful, sensual beauty of the music it recreates. The first thing that will strike you about your new SLI-30 integrated amplifier is the incredible transparency and resolution of detail in the music. The SLI-30's sensual nature is best revealed in the sense of life it displays in female vocalists.

Your new Cary SLI-30 integrated presents music with such presence and directness, you'll be drawn into the music hour after musically satisfying hour. This is the result of circuit techniques, which eliminate any discernible crossover notch at low levels, and also contributes to the freedom from listening fatigue. The SLI-30 will draw you in even further as you realize how lucid and utterly uncolored neutrality reveals delicate nuances in the sound stage.

Enjoy the music and of course please read this complete manual for a complete understanding of trouble free operation.

SPECIFICATIONS

Operating the SLI-30 stereo integrated amplifier is a simple procedure, since each unit is designed for long term stability in virtually any home operating situation. Therefore, if the unit is operated outside the parameters outlined in this owner's manual, damage may result. Please read this manual carefully before putting your new Cary Audio Design SLI-30 in operation.

The following definitions are applicable to this manual. These definitions must be followed explicitly.

WARNING
HAZARD PRESENTS PERSONAL INJURY OR DEATH

Caution
EQUIPMENT DAMAGE MAY OCCUR BUT NOT PERSONAL INJURY

Note
Proper performance of the amplifier cannot be ensured
if disregarded

1.2 Specifications

The following section describes the SLI-30 basic specifications. Specs are subject to change without notice or obligation.

DIMENSIONS: 4"H x 17"W x 12"D

WEIGHT: 34 lb.

CIRCUIT TYPE: Push-Pull Ultralinear Amplification in Class AB

POWER OUTPUT: 1khz sign wave
11 volts RMS across 4 ohms = 30 watts
15.5 volts RMS across 8 ohms = 30 watts

INPUT SENSITIVITY: .420 volts for full output

INPUT IMPEDANCE: 100,000 ohms

NOISE AND HUM: 80db below rated output

FREQUENCY RESPONSE (at full power output): 20Hz to 30,000Hz + 0 - 0.75db

DAMPING FACTOR: Greater than 35

TUBES: 2 - 12AX7 pre-driver phase inverter
8 - EL-84 push-pull output circuit

TRANSFORMERS: 1 - EI laminated core power transformer
2 - EI laminated core output transformers
150% duty cycle on all transformers

RESISTORS: 1% metal film

CAPACITORS: polystyrene and polypropylene

POWER SUPPLY CAPACITORS: Six 820 MFD @ 400 VDC
TOTAL 2460 MFD - 224 Joules

AC CORD: 3 conductor shielded detachable

AC POWER REQUIREMENTS: 117 volts AC 50/60Hz
220 watts operate
90 watts in stand-by
234 volts AC 50/60Hz
220 watts operate
90 watts in stand-by

PC BOARD: G-10 Glass double sided plated through

WARM-UP TIME: 3 minutes

BREAK-IN PERIOD: 100 hours of music playing time

FINISH: Black baked on epoxy paint over aluminum chassis

FRONT PANEL: Machined, anodized aluminum

1.3 Front Panel Features

AC-ON-STAND BY, OPERATE: Rotary switch turns on AC mains and high voltage on "in operate" position

LED: Indicates AC power on

EARPHONE: 3 conductor stereo headphone jack for low impedance earphones

OUTPUT SELECTOR: Switches amplifier output from speakers to earphone listening

LISTENING LEVEL: Dual precision potentiometer controlling volume of both channels

LEVEL CONTROL L, R: To be used as a balance between left and right channel

INPUT SOURCE: Selection of line inputs for listening

1.4 Rear Apron Features

INPUTS: Signal input connection via shielded interconnect cable

TAPE OUT: Steady level output to recorder input

SPEAKER OUTPUT: The 5-way binding posts provide the output to the speaker system. Red = +, Black = -.

GND: For “audio purists” this should be connected to an earth ground rod via the shortest lead possible - this is not essential for proper operation. The earth ground will help insure immunity to RF interference and AC ground loops.

CAUTION
EQUIPMENT DAMAGE MAY OCCUR WITH IMPROPER FUSES

AC FUSE: This is an over current protection fuse for the SLI-30.
Never replace with any other fuse than 2 AMP SLOW BLOW!
250 VOLT! (2 AMP SLOW BLOW ON 220 VAC OPERATION)

AC: 3 conductor shielded power detachable cord to AC power mains

CAUTION
NEVER REMOVE / INSERT AC LINE CORD WHEN THE UNIT IS ON

LPP-1 ACCESSORY PLUG: Supplies voltage to LPP-1 phono amplifier

INSTALLATION

This section describes the unpacking and installation procedures for the SLI-30 amplifier.

WARNING

MAKE NO ATTEMPT TO PUT THE SLI-30 AMPLIFIER IN SERVICE WITHOUT THE BOTTOM PLATE ATTACHED - CONTACT WITH VOLTAGE IN THE SLI-30 CAN BE FATAL!!!!

2.1 Unpacking

All shipping containers have been specifically designed to protect their contents and special care has been taken to prevent damage under normal shipping conditions. Mishandling should be evident upon inspection of the shipping container. If damage is found after visual inspection, take care not to destroy the evidence. If necessary, document the damage with photographs and contact the transport carrier immediately.

Carefully remove your new SLI -50 stereo integrated amplifier from its packing carton, and examine it closely for signs of shipping damage. It is recommended to save all original packing cartons to protect your amplifier from damage should you wish to store it or ship it for after-sales service.

2.2 Warranty Card

Fill out the enclosed warranty registration card and return it to Cary Audio Design, Inc. within 10 days of original purchase. Keep your original sales slip with the packing cartons should you ever need it for reference. **Failure to register warranty will limit the warranty to one year.**

2.3 Amplifier Placement

In general, the location of your new SLI-30 is not critical. Certain precautions must be taken to ensure optimum performance. Avoid extremely hot locations such as near radiators or other heating units. Keep the top of the SLI-30 clear of books, paper or other equipment to protect against overheating!! DO NOT place your SLI-30 in a closed book case - overheating will damage the amplifier! Allow 8 to 10 inches above the unit for proper ventilation.

2.4 Power Requirements

The SLI-30 is designed to operate from house current mains. The design voltage is 117 VAC at 50/60Hz. (Foreign units 234 VAC at 50/60Hz.)

2.5 Cables

The speaker cables from the output posts of the SLI-30 to the speaker system can be any convenient length your set-up requires. Select speaker cables of sufficient size to preserve the outstanding performance capabilities of your SLI-30. Heavy gauge #16 wire is suitable for distances up to 10 feet; #12 for 25 feet. Most audio dealers will have proper speaker cable in stock for this purpose.

OPERATION

Signal input connection is made via the input jacks on the rear of the SLI-30 located on the rear panel. The interconnect cables from the output of the CD player, tuner, etc. can be any convenient length your set-up requires. The choice of a high quality interconnect cable is important. Once again, your audio dealer will have the proper cables in stock for this purpose.

3.1 Operation

Your new SLI-30 is ready for operation after the speaker and interconnect cables have been installed.

3.2 AC On Stand By Power Switch

Simply turn the rotary switch to the "stand by" position. The high voltage will slowly come up and the blue LED will light and indicate the power supply is charged. After 1 to 2 minutes turn the switch to "operate". Observe that all 10 tubes are lit (filaments). Waiting 1 to 2 minutes before switching to "operate" is not absolutely necessary, but warming up the filaments before applying high voltage will extend the life of your tubes.

3.3 Stand By Switch

This is a most convenient feature on the SLI-30 amplifier. In the "operate" position, the amplifier is ready to operate. In the "stand by" position, only the tube filaments are operating. You may wish to leave your SLI-30 amp turned on in the "stand by" mode 24 hours a day. When you wish to listen to music simply turn the stand by switch to the operate position. Under these conditions the SLI-30 is always warmed up and ready for peak performance.

3.4 Break-In Period

The tubes, capacitors and output transformers take approximately 100 hours of music playing to fully settle in for peak performance. The SLI-30 will seem sterile or thin sounding right out of the box. After the first couple of hours you will notice increased depth and tighter bass. This break-in period defies all engineering theory, but is true with most audio amplifiers.

<p style="text-align: center;">WARNING MAKE SURE AMPLIFIER IS UNPLUGGED FROM AC MAINS BEFORE SERVICING</p>

SERVICE AND CARE

4.1 SLI-30 Care and Cleaning

The case and front of the SLI-30 may be cleaned with a soft cloth and Windex or a window cleaner. The frequency of cleaning will be governed by how many hours the SLI-30 is operated and by operating environment cleanliness. A very mild chrome polish may be used on the chrome chassis to remove what the window cleaner does not. **CAUTION!** Gently apply the polish to the chrome, otherwise you may scratch the chassis.

4.2 Tube Replacement

If it becomes necessary to replace the tubes in the SLI-30 amplifier, a matched quartet set of output tubes of the same brand should be used. A new tube kit is available from Cary Audio Design, Inc. You should get a few years or more from the output tubes with everyday usage and many, many years of use from the 12AX7 input tubes.

4.3 SLI-30 "TWEAKS"

If you are technically inclined with an electronic background and would like to elevate your new SLI-30 to an even greater performance level, you may wish to include some of the following upgrade tweaks:

7189 OUTPUT TUBES: The 7189 beam power pentode tubes have a higher plate and screen dissipation than the standard 6BQ5/EL84. The power output of the SLI-30 increases to 34 watts per channel with 7189 tubes utilized in the output section. We estimate much longer output tube life with the 7189's installed in a SLI-30.

5751 INPUT TUBES: This high-mu twin triode is a premium rated vacuum tube that will offer you incredible detail and air in the music. This military, commercial tube is rated in terms of "shock, fatigue, low-frequency vibration" with a minimum of 2,000 heater turn on and off from cold start operations. The noise floor of the SLI-30 is down an additional 8dB using the 5751's as the input tubes.

7025 INPUT TUBES: The 7025 twin triode made by GE is the perfect tube for lovers of the old tube sound of years ago. In the SLI-30 this low noise, low hum tube will give a sound system all the warmth and mid-range bloom needed with many so-called 7025/12AX7's on the market. They are mostly just 12AX7's marked 7025. As of this writing, the only true 7025 in production is made by GE.

EDDISON PRICE

SPEAKER POSTS:

One of the finest heavy duty 5-way binding posts available. Pure copper with plenty of space for bi-wiring even the heaviest speaker posts. All one needs to add these marvelous post to the SLI-30 is an adjustable wrench and a large soldering iron. The sonic merits include better bass extension and high frequency detail.

OIL FILLED .22

COUPLING CAPS:

Very expensive and exotic up-grade. The closest one is able to get to the ideal of no resistance, no leakage and no inductance. Of course, in practice, all caps have some of the above deficiencies. The ideal capacitor is not possible, but these oil filled are the ideal cap for AC audio coupling from the phase-inverter to the output tubes in your SLI-30. A word is in order about the stock coupling caps in the SLI-30. Cary Audio Design utilizes very high quality caps as a stock item in your SLI-30. They are 600 volt .22 polystyrene. The oil filled are far too expensive to use as a standard part in production and still offer such a reasonable price on the mighty SLI-30. With the .22/600VDC oil filled caps installed in the SLI-30 you will have a mid-range bloom as never before along with incredible bass definition. The highs will come through as if "liquid syrup" was filling the sound stage. This is the most important improvement, along with adding 7189 output tubes, one could make on an SLI-30. These caps must be soldered to the PC board, so one must have the expertise to solder when upgrading with the oil filled coupling caps.

CARY "TIP TOES":

The hard rubber feet on your SLI-30 can be unscrewed and replaced with the black anodized aluminum Cary Tip Toe feet for unbelievable isolation of the SLI-30. Vibrations from the music in the listening room can cause colorations on the audio amplifier and preamplifier. Utilizing these isolation feet will dramatically float the SLI-30. A very simple tweak to perform. The tip toes are threaded with a 6/32 center hole so they may be sued on all types of equipment.

All of these upgrade SLI-30 tweak parts are available from your Cary Audio Design dealer. For additional information on the art of tweaking your SLI-30, please feel free to call the Cary Audio service department at (919) 481-4494. **ENJOY.....**

4.3 FACTORY SERVICE

Careful consideration has been given to the design of your SLI-30 amplifier to keep maintenance problems to a minimum. However, it is possible that some problems may arise which cannot be cured by tube substitution. At this point we suggest you contact our Customer Service Department phone number (919)481-4494 to describe your problem in detail. DO NOT return the SLI-30 to the factory without a return authorization number from the Customer Service Department.

Cary Audio Design, Inc. will assume no responsibility if the transportation company refuses to pay a damage claim due to your improper packing or lack of insurance should the unit be lost or damaged in shipment.

WARNINGS

MAKE NO ATTEMPT TO PUT THE SLI-30 IN SERVICE WITH THE BOTTOM PLATE REMOVED. CONTACT WITH HIGH VOLTAGES FOUND IN THE UNIT CAN BE FATAL!! COMPLETELY REMOVE AC POWER PLUG FROM THE WALL AND ALLOW 30 MINUTES FOR THE HIGH VOLTAGE CAPACITORS TO DISCHARGE THROUGH BLEEDER RESISTORS BEFORE ATTEMPTING TO CHANGE TUBES OR CLEAN THE INSIDE OF THE AMPLIFIER

CAUTIONS

NEVER REMOVE / INSERT AC PLUG WHEN THE UNIT IS ON OR THE AC POWER SWITCH IS IN THE ON POSITION. OBSTRUCTION OF THE TOP PORTION OF THE SLI-30 WILL RESULT IN TUBES OVERHEATING AND DAMAGE TO THE AMPLIFIER.

!!OBSERVE DIRECTIONS IN THIS MANUAL!!

Notes:

UNITED STATES LIMITED WARRANTY

Cary Audio Design, Inc. warrants to the original United States purchaser for use in the United States, that this product shall be free from defects in material (except tubes and AF output transistors) or workmanship for:

Amplifiers and Preamplifiers, Three (3) years from the date of the original purchase.

Digital Products, One (1) year from the date of original purchase

During the warranty period, Cary Audio Design, Inc. or an authorized Cary Audio Design, Inc. service facility will provide free of charge both parts (except tubes and AF output transistors) and labor necessary to correct defects in material or workmanship.

To obtain such warranty service, the original purchaser must:

- (1) Complete and send in the warranty Registration Card.
- (2) Notify Cary Audio Design, Inc. as soon as possible after the discovery of a possible defect:
 - (a) The model number and serial number;
 - (b) The identity of the seller and the approximate date of purchase;
 - (c) A detailed description of the problem, including details on the electrical connection in the associated equipment and the list of such equipment.
- (3) Deliver the product to Cary Audio Design, Inc. or the nearest authorized service facility, or ship the same in its original container or equivalent, fully insured and the shipping charges prepaid.

Correct maintenance, repair and use are important to obtain optimum performance from this product. Therefore, carefully read the Operating Manual. This warranty does not apply to any defect that Cary Audio Design, Inc. in its sole discretion determines is due to:

- (1) Improper maintenance or repair, including the installation of parts or accessories that do not conform to the quality and the specifications of the original parts.
- (2) Misuse, abuse, neglect or improper installation.
- (3) Accidental or incidental damage.

WARRANTY DISCLAIMER

Except for the express warranties stated herein, Cary Audio Design, Inc. disclaims all other warranties including, without limitation, all implied warranties of merchantability and fitness for a particular purpose.

EXCLUSIVE REMEDY

Notwithstanding the foregoing, the purchaser's exclusive remedy for any breach of warranty, express or implied, is limited to the repair or replacement of the defective unit or the refund of the purchase price, at the option of Cary Audio Design, Inc. Under no circumstances is Cary Audio Design, Inc. liable for incidental or consequential damages. Any implied warranties imposed by law terminate one (1) year from the date of purchase.

FOREIGN PURCHASERS

Cary Audio Design, Inc. warrants its merchandise to purchasers in the United States for use in the United States. It provides no other warranties. If you are a foreign purchaser, consult with your dealer to determine whether your dealer provides any warranty.

The foregoing constitutes Cary Audio Design Inc.'s entire obligation with respect to this product, and the original purchaser and any user or owner shall have no other claim for incidental or consequential damages. Some states do not allow the exclusion or limitation of incidental or consequential damages, so the above limitation and exclusion may not apply to you.

This warranty gives legal rights and you may have other rights which vary from state to state.

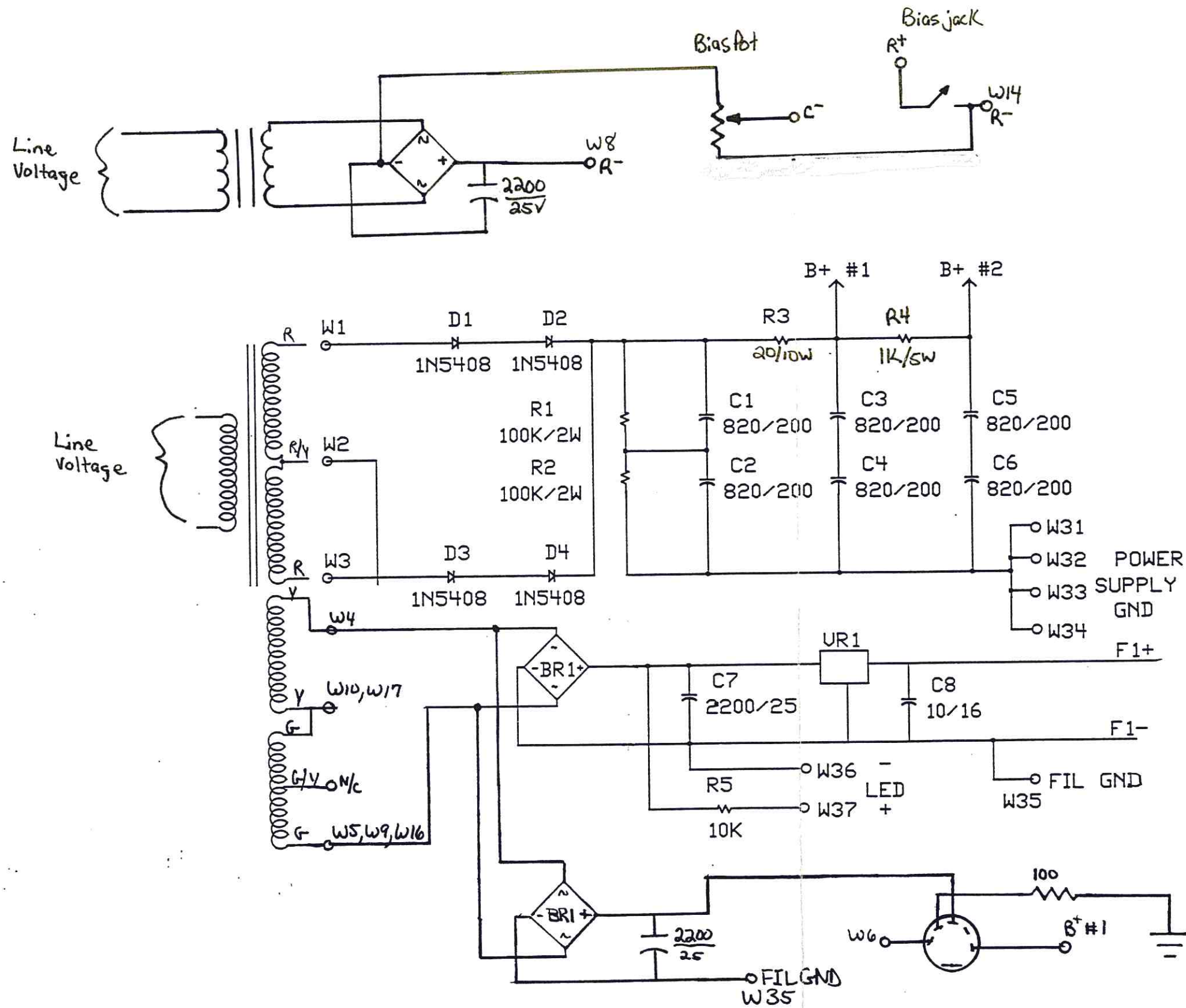

5LI-3D
power supply

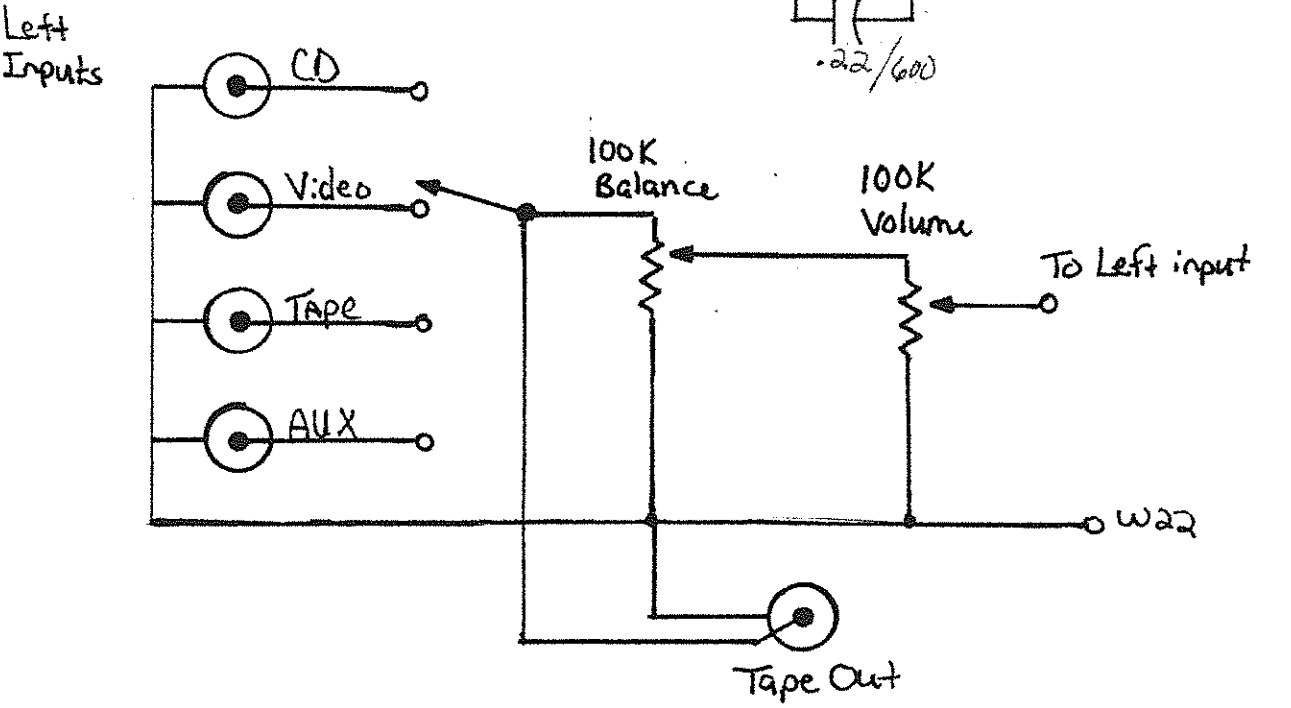
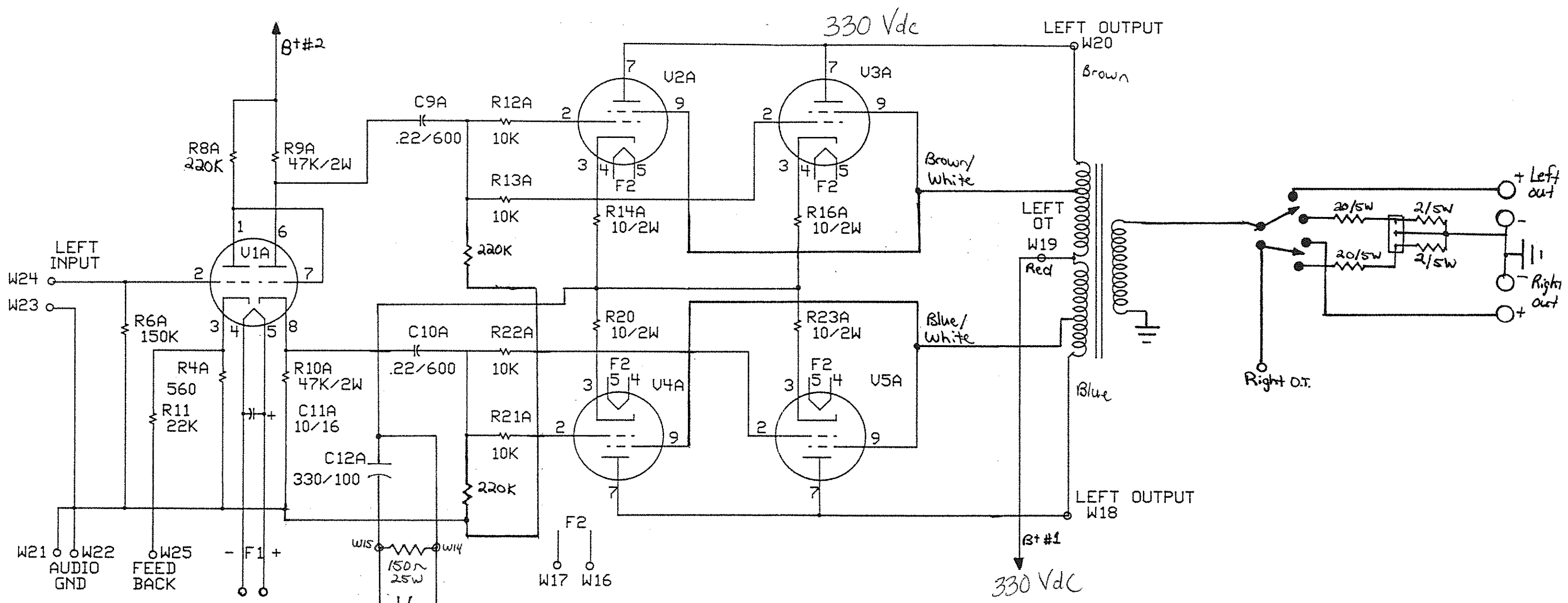

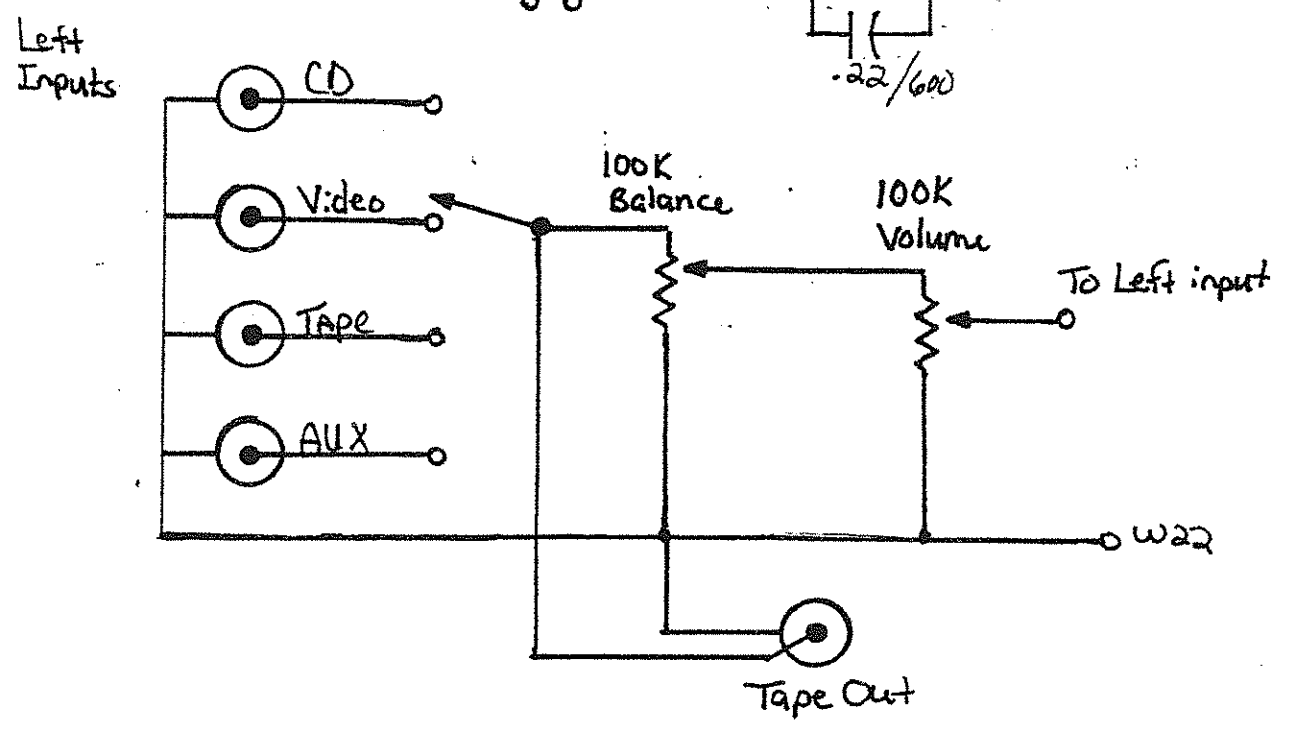
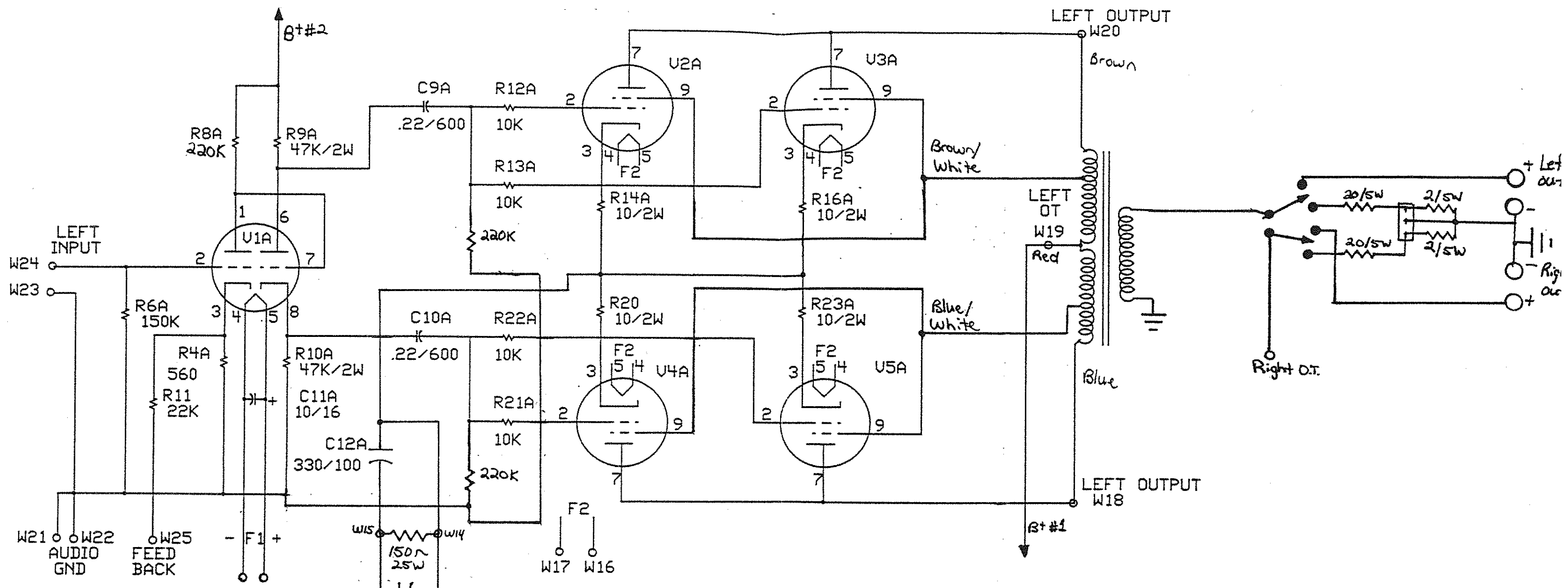

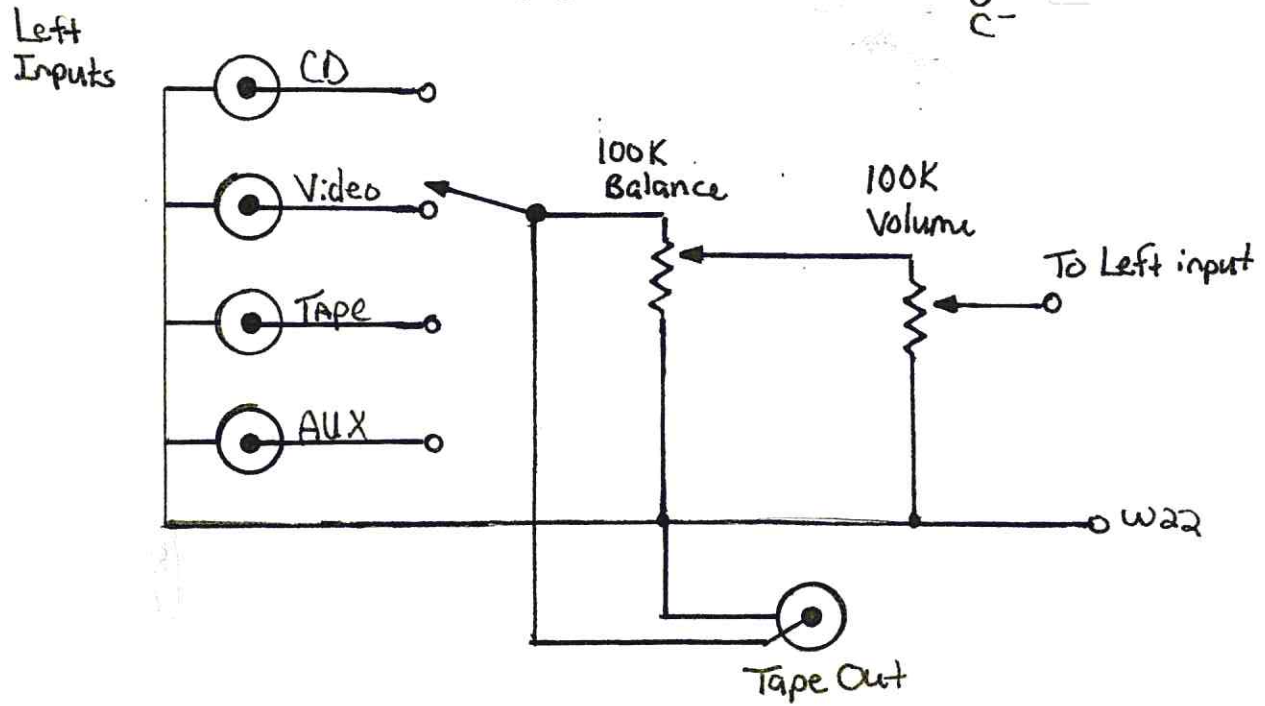
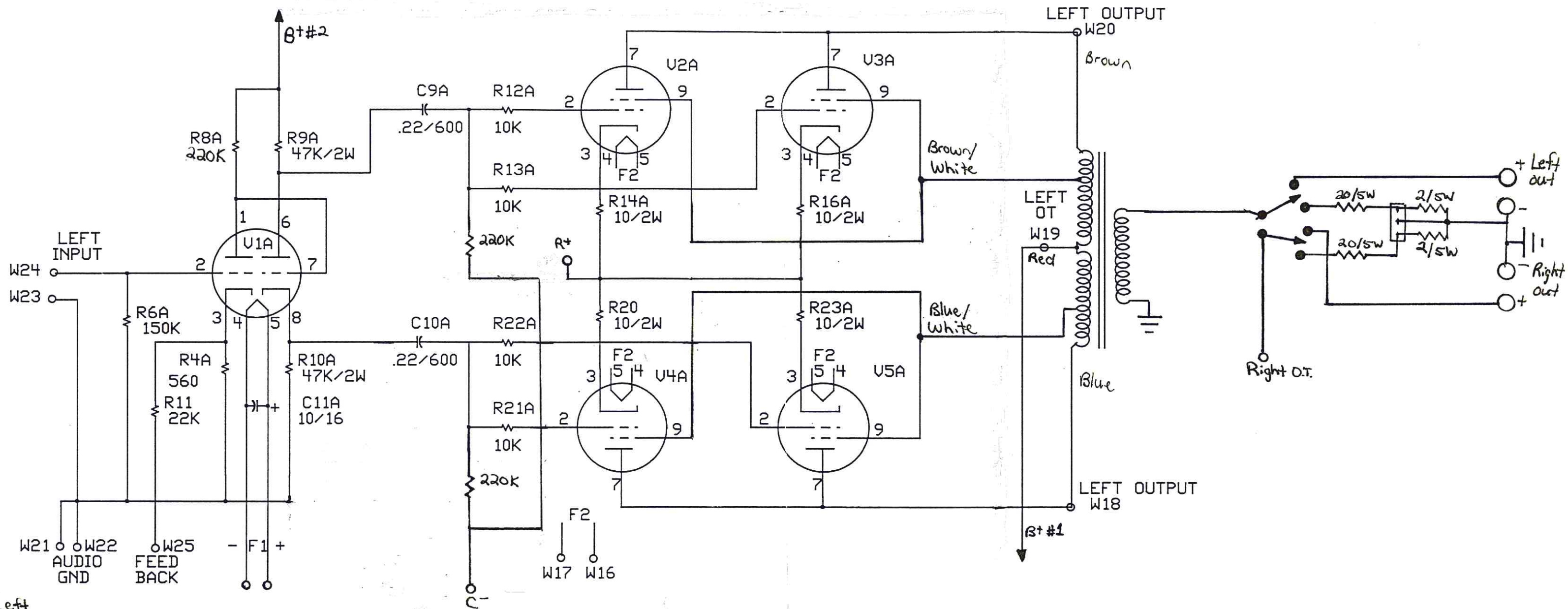

SLI-30

CARY

Audio Design

111-A Woodwinds Industrial Court
Cary, NC 27511
USA

Phone: 1-919-481-4494

Fax: 1-919-460-3828

www.caryaudio.com

info@caryaudio.com